

2137 Roosevelt Avenue • Racine WI 53406 • Phone: (262) 633 – 3703 • Fax (262) 423 – 6743
www.WindowWellSupply.com

Steelway KD Cellar Door Frame Assembly

Assemble using (10) 1/4" round head bolts, and nuts, with bolt heads facing out.

STEP 1:

Attach header piece to side pieces. Header must lay on top of side pieces.

STEP 2:

Attach header notch to side piece flange. Apply caulk to seam before fully tightening this bolt.

STEP 3:

Attach sill plate to lower side piece flange. Check frame is square before tightening all bolts.

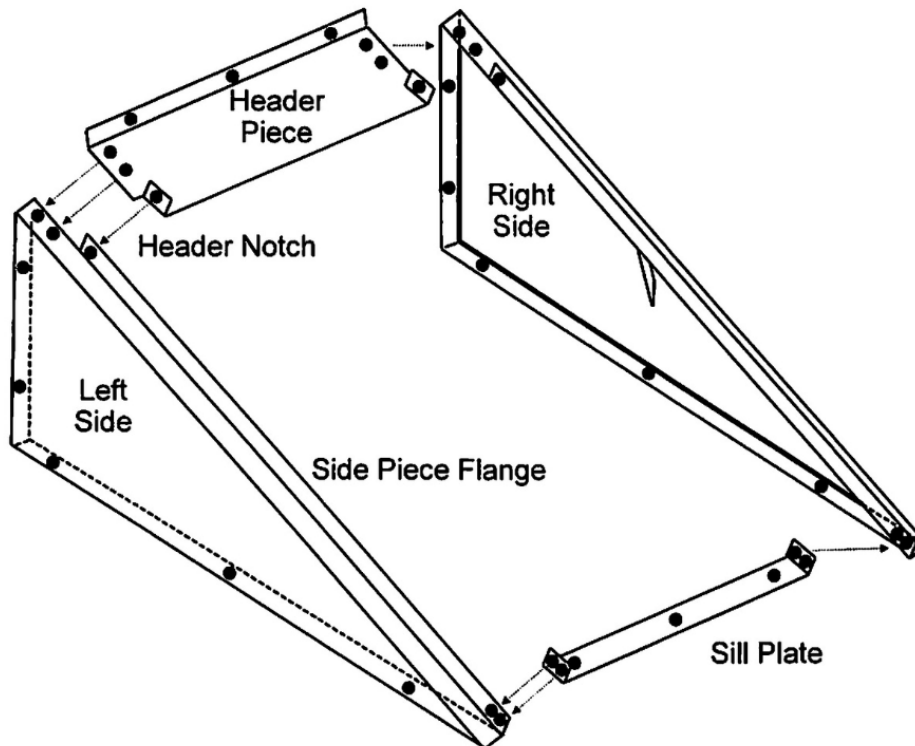

INCLUDED HARDWARE:

- | | |
|-----------------------------------------|------------------------------------|
| (20) 1/4" x 1/2" round head bolts | (2) Side rail piston brackets |
| (16) 1/4" x 1" plastic concrete anchors | (2) Door panel piston brackets |
| (16) 1/4" x 1-1/4" anchoring screws | (2) Gas pistons |
| (4) 5/16" x 1-1/4" pins and cotter pins | (1) Handle |
| (18) 1/4" nuts | (2) Washers (use with handle only) |