

STEELWAY STAIR STRINGER Installation Instructions

The Steelway Stair Stringer now makes it easy and economical to add stairs to your new or existing bulkhead. Along with the Steelway Steel Basement Door, the Steelway Stair Stringers eliminate the need for expensive and complicated step construction. Made of 14 gauge galvanized steel and prepunched for easy tread installation.

1. First measure the 'H' dimension, then the 'F' dimension. If new areaway, build to specifications below for model desired.

2. Second, select the right size Steelway Stair Stringer:

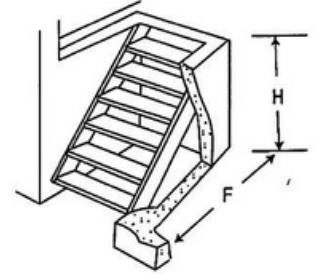

Select Stringer	'H'	'F' At Least	Length of Stringer	Number of Steps	Use Basement Door Model
ST-3	30"-34"	26-3/8"	33"	3	
ST-4	35"-40"	34-5/8"	44-7/8"	4	"SL"
ST-5	41"-47"	43-3/8"	56-3/4"	5	
ST-6	48"-55"	51-3/8"	68-1/2"	6	"O"
ST-7	56"-64"	59-3/4"	80-1/2"	7	"B"
ST-8	65"-72"	68-1/2"	92-1/4"	8	"C"

How to Install the STEELWAY STAIR STRINGERS

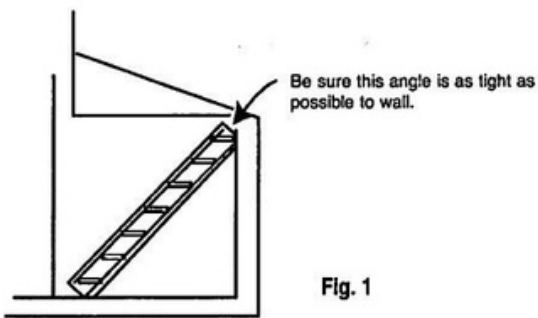

Fig. 1

STEP 1 Set level on convenient eye level tread cut-out (Fig. 1). Move STEELWAY STAIR STRINGER in and out/up and down so That top angle is as straight as possible to outer wall.

STEP 2 SECURE STEELWAY STAIR STRINGER with either masonry Nails or screw anchors and lag bolts use at least 6 nails or bolts. (**NOTE:** If anchoring into concrete block be sure nail or lag screw And anchor are not in hollow part of block. If so use appropriate size toggle bolts.)

STEP 3 CUT STEPS from 2" x 10" lumber. The cut size will be 2" less than the width between the walls supporting the STEELWAY STAIR STRINGER.

STEP 4 SECURE SECOND STRINGER by placing it Against wall and inserting a stair tread in bottom cut Out and another at eye level cut out. Move second Stringer in and out up and down until stair treads are Level. Secure second stringer as in Step 2.

STEP 5 SECURE STAIR TREAD (Fig. 2) by driving an 8d nail straight down into the tread through the hole Provided in the STEELWAY STAIR STRINGER.

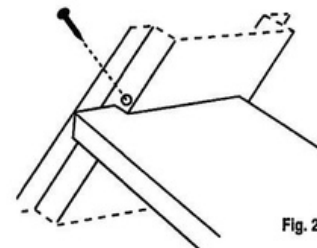

Fig. 2